

6

5

4

3

2

1

D

C

B

A

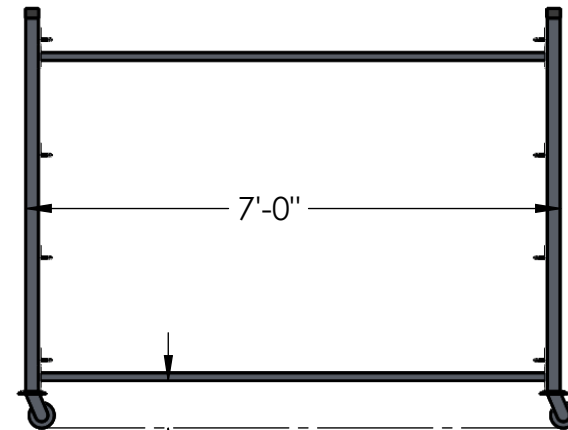
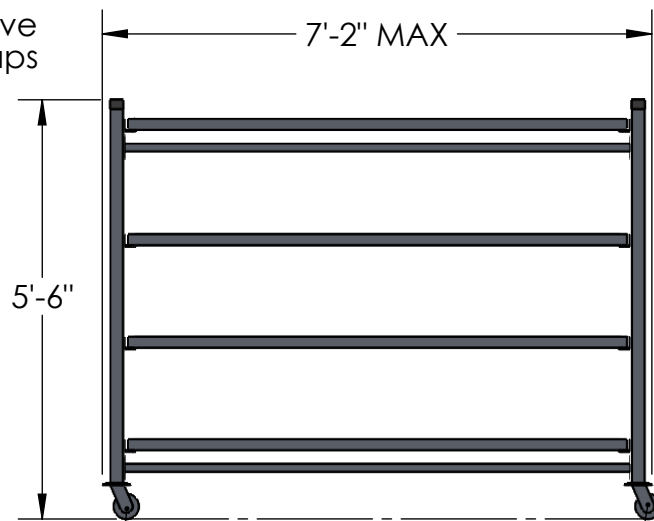
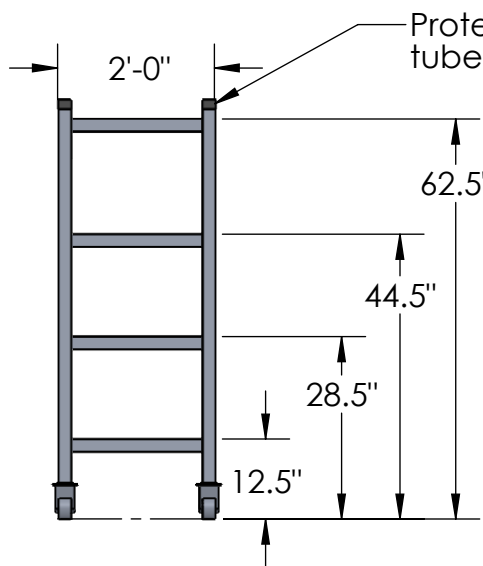
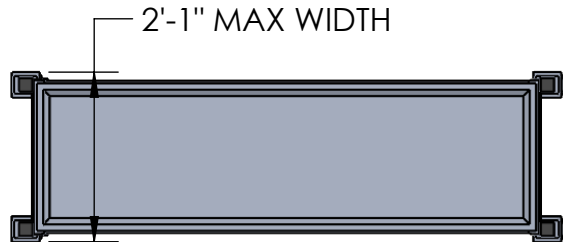
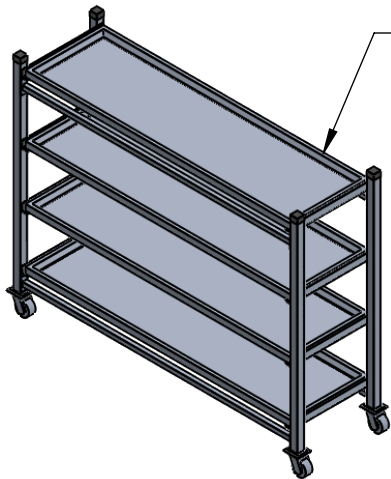

2x Swivel casters

2x Swivel & lock casters

7.5" CLEARANCE



1 (800) 940-0508 www.ancelatruck.com

**PROPRIETARY AND CONFIDENTIAL**  
 THE INFORMATION CONTAINED IN THIS DRAWING IS THE SOLE PROPERTY OF ACELA TRUCK COMPANY. ANY REPRODUCTION IN PART OR AS A WHOLE WITHOUT THE WRITTEN PERMISSION OF ACELA TRUCK COMPANY IS PROHIBITED.

PRODUCT

Acela - 53' Morgue Trailer

DRW REV. A

SHEET 5 OF 5

SCALE 1:192

MATERIAL N/A

FINISH N/A

UNLESS OTHERWISE SPECIFIED DIMENSIONS ARE IN INCHES

0.X ± 0.1  
 0.0X ± 0.01  
 0.00X ± 0.005  
 ANGULAR ± 1°

3RD ANGLE PROJECTION

